

# superset nt

automatic throughfeed moulder



Suppers

# DISCOVER SUPERSET NT, DESIGNED FOR YOU.



## QUALITY



### **Increased productivity**

The SET-UP system allows the operator to change tools and perform adjustments in just a few seconds, making set-up time up to twenty times faster.

## EFFICIENCY



### **Maximum flexibility**

The machine is able to process work-pieces with variable dimensions, 15x6 mm minimum finished section and 260x200 mm maximum finished section.

## VERSATILITY



### **Customised compositions**

Ten possible configurations thanks to two right vertical spindles, two top horizontal spindles, with and without universal spindle.

## STRENGTH



### Finish quality

Tool-holder spindles made of hardened steel cylinders with larger dimensions (120 mm) and double pair of bearings, to ensure rigidity and accuracy.

## RELIABILITY



### Ergonomic

The machine structure has been specifically designed to enable the operator to work in ergonomic and safe conditions.

## INNOVATION



### Ease of use

The MOBILE PC electronic control makes machine programming intuitive. Clear and precise information are always available, thanks to detailed reports.

26

SOFTWARE

33

TECHNICAL DATA

# TECHNICAL FEATURES OVERVIEW

TECHNOLOGICAL ADVANTAGES



**Feed system**  
Maximum flexibility.

Ten possible configurations  
Customised compositions

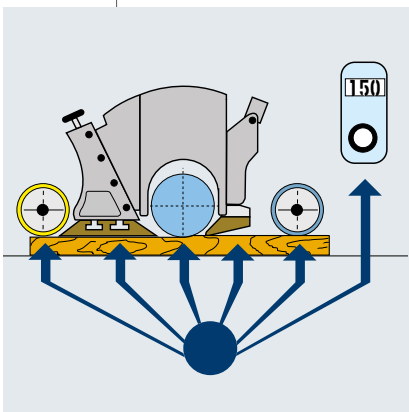

**SET-UP system**  
Increased productivity.



**Machine structure**  
Ergonomic.

# nt



**MOBILE PC electronic control**  
Ease of use.



**Worktable**  
Finish quality.

# STRUCTURE

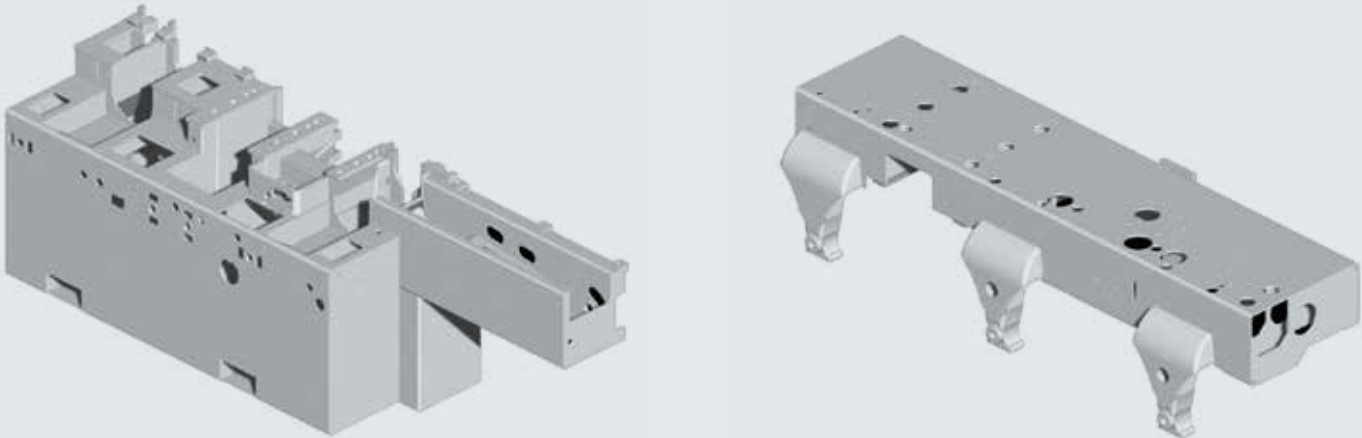

Machine bed and top beam are monobloc constructions in thick steel, guaranteeing total lack of vibrations to achieve a high quality finished product.  
 Each composition has its specific structure.

## CUSTOMISED COMPOSITIONS

Ten possible configurations thanks to two right vertical spindles, two top horizontal spindles, with and without universal spindle.

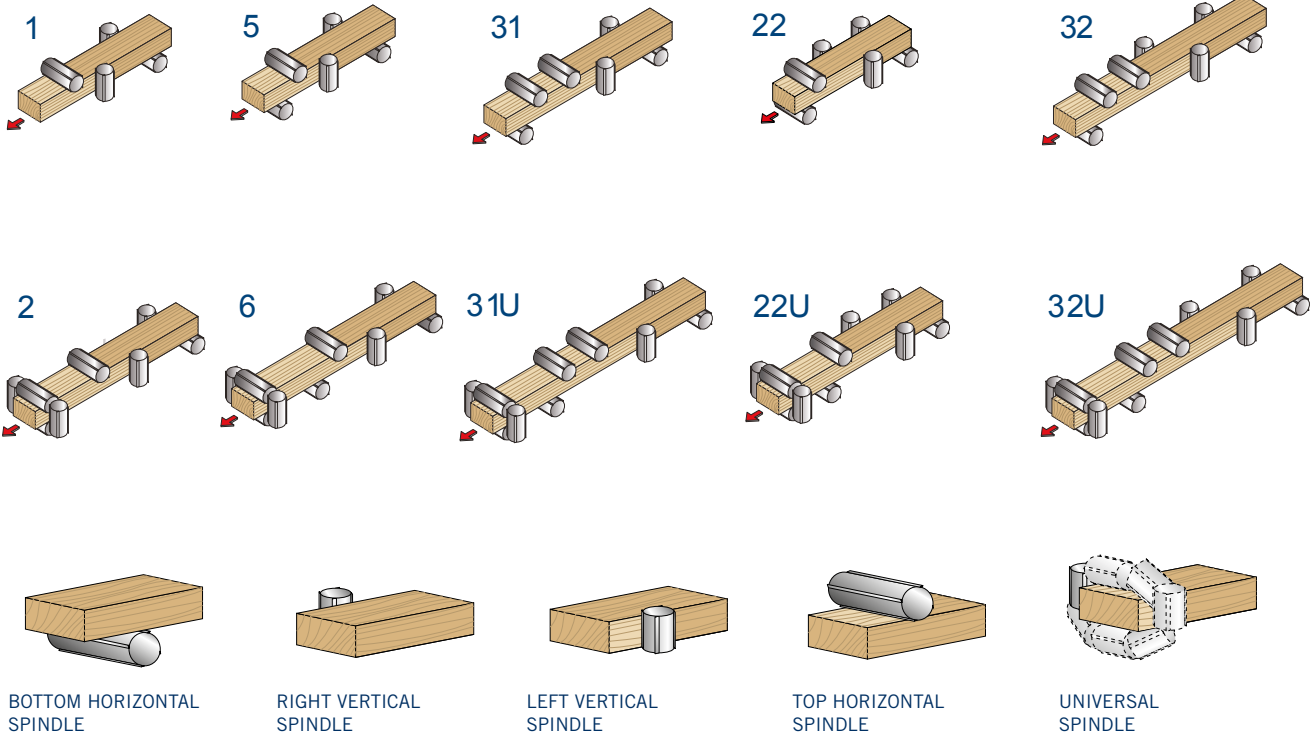





The machine structure has been designed to enable the operator to work in ergonomic and safe conditions. Maximum reliability during tool change operations, special supports allow to hang the dust collection covers directly on the machine.

The eye-M console is integrated in the machine base and it can be orientated for the best operator's comfort during the programming.



# WORKTABLE



The infeed worktable of tubular steel is equipped with a hardened insert placed before the planer spindle, that ensures maximum stability during the processing of work-pieces, including those with large dimensions.



## **GROOVED WORKTABLE**

It is specific for short, warped or poorly finished work-pieces, fitted with an integrated fence system.

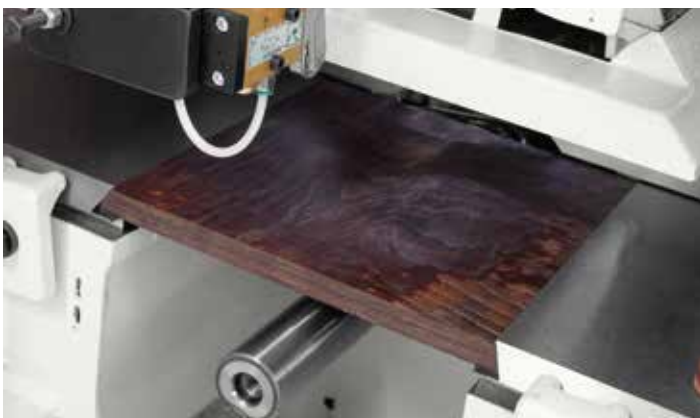

## **REXILON WORKTABLE**

Located above the bottom horizontal spindle, it allows profiling depth up to 50 mm, guaranteeing the worktable continuity.

Excellent finish with the air blower. The device is made of four rows of holes which create an air cushion on the worktable; each row of holes is activated according to the work-piece width. Together with the worktable lubrication (also automatic), they enable the perfect sliding of the work-piece.



For 32 and 32U compositions, it is possible to supply two feeding rollers in the worktable, before and after the 1<sup>st</sup> top horizontal spindle, to enhance the constant towing of the work-pieces.

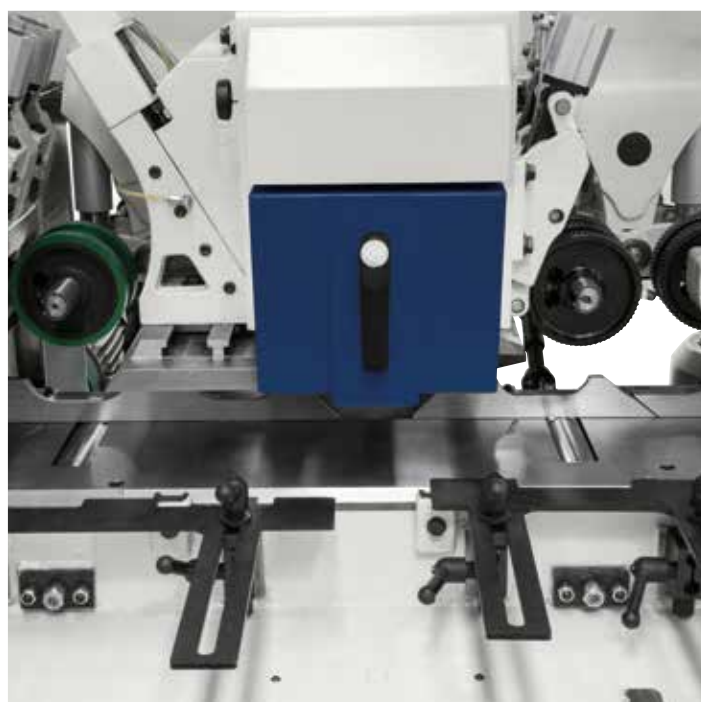

# FEED SYSTEM

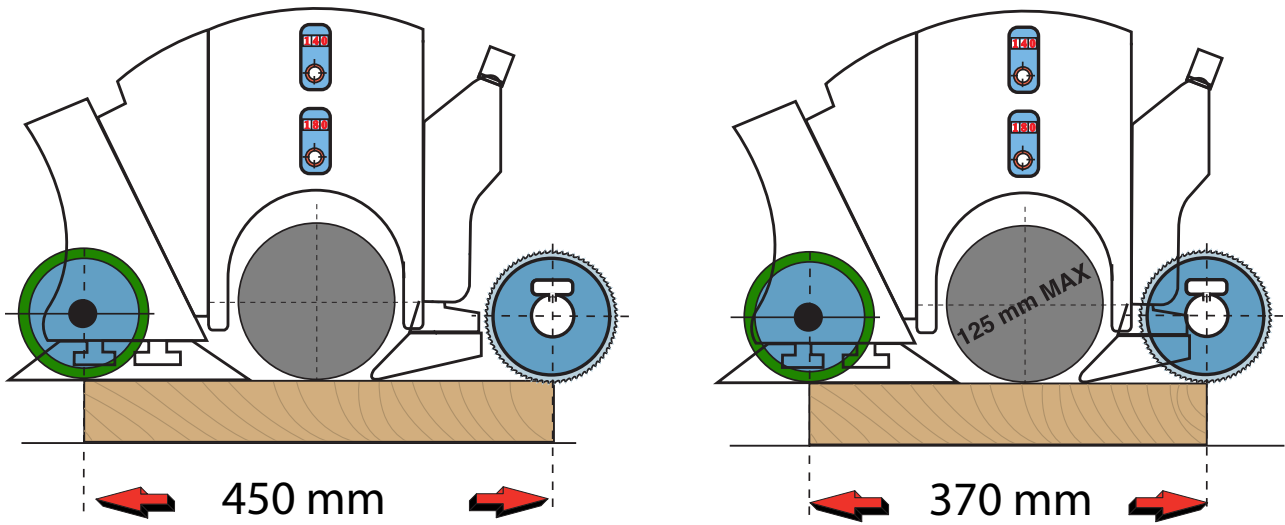

## SINGLE WORK-PIECE MACHINING

In standard configuration, the machine can process a work-piece of 620 mm length; with specific options it is possible to reduce the work-piece length to 450 or 370 mm.





#### **TANDEM UNIT**

It reduces the axial distances between the wheels and improve the work-piece pressure system in the machining area.

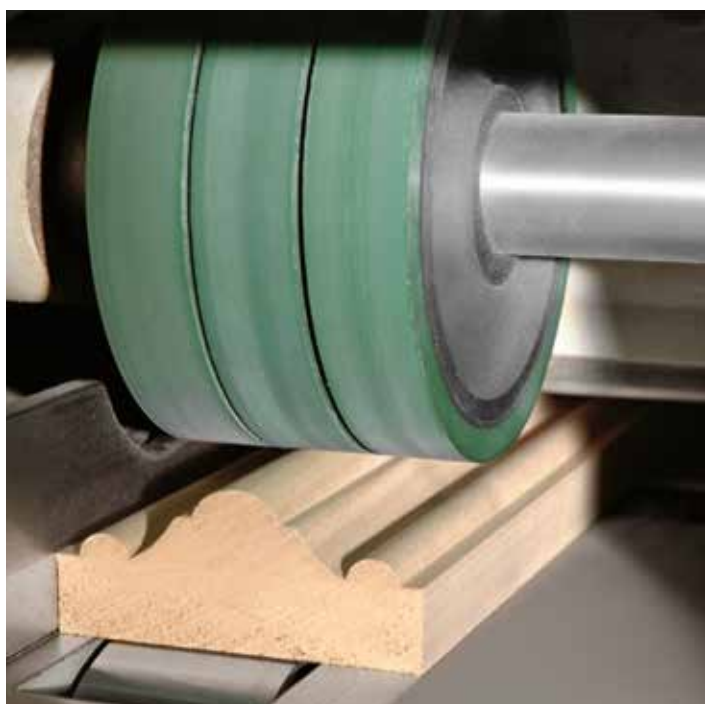

#### **RUBBER COATED ROLLERS**

After the processing of the top horizontal spindle, only rubber coated rollers are provided, in order to avoid damaging the work-piece surface.

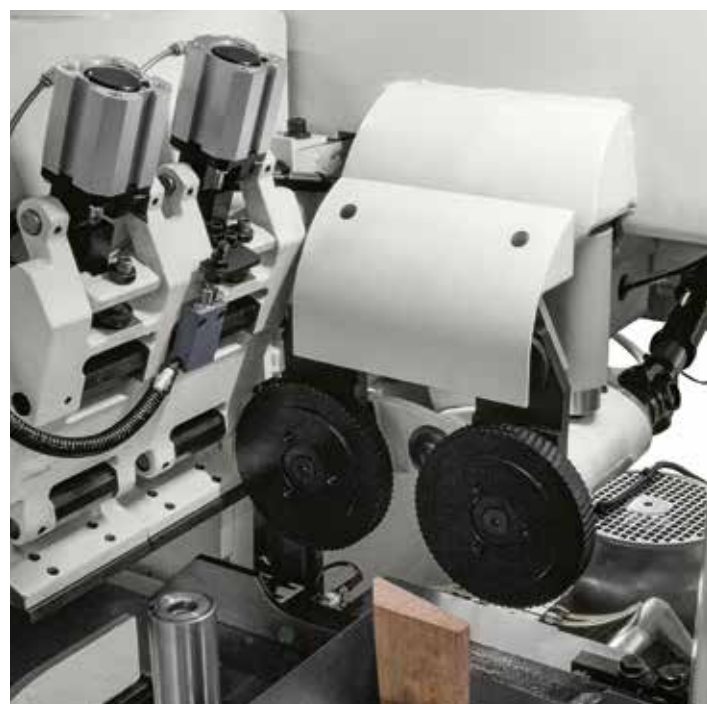

#### **TELESCOPIC WHEELS**

Placed in front of the left vertical spindle with electronic adjustment and 75 mm stroke, for optimal towing of any work-piece width.

# RIGHT AND LEFT FENCES

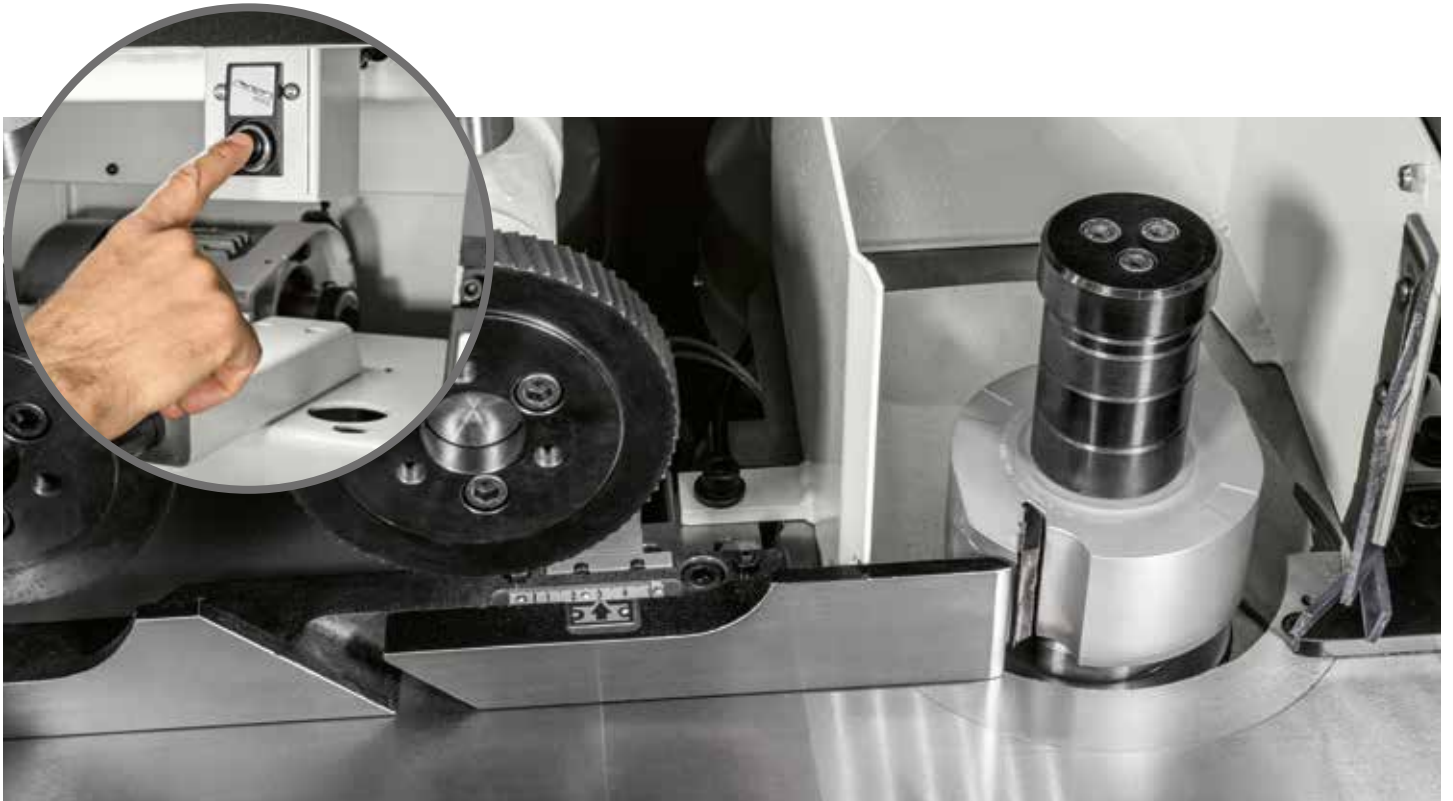

## RIGHT FENCE WITH ADJUSTABLE SECTOR

Rapid set-up: by using a pneumatic selector, the operator can quickly adjust the fence to the correct position, according to the tool dimensions.



## LEFT FENCE

Fewer adjustments to be performed due to the possibility of having a single fence (optional for 31 and 31U compositions) at the end of the machine, with pneumatic locking, for uniform pressure over the entire work-piece.

**ELECTRONIC LEFT FENCE FOR 32 AND 32U COMPOSITIONS**

Fence position for machining a work-piece of maximum width.

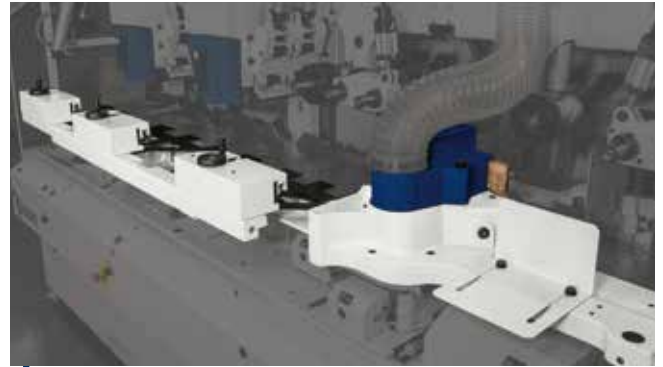

Fence position for machining a work-piece of intermediate width.

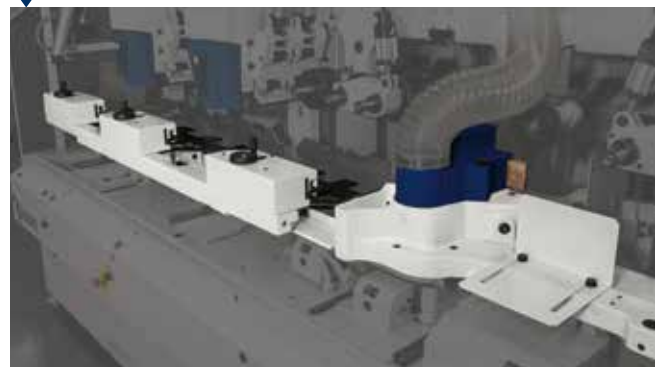

Fence position for machining a work-piece of minimum width.

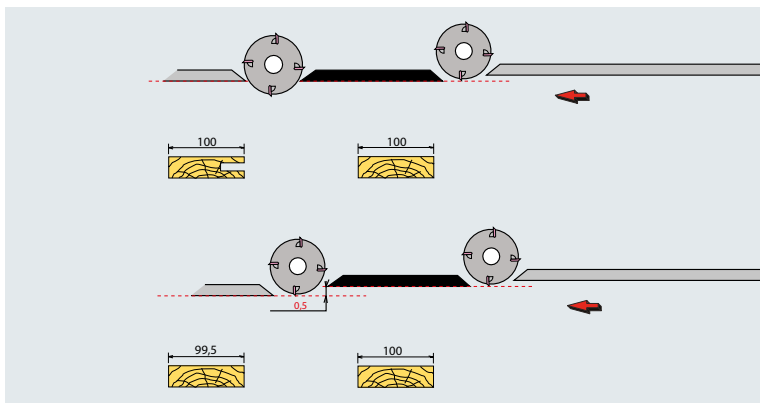
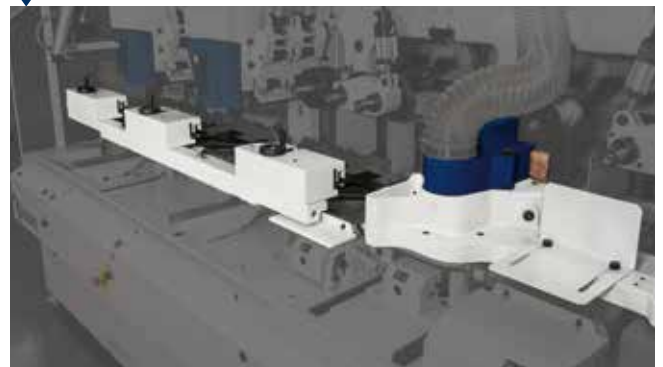

**RIGHT FENCE WITH ON/OFF**

Pneumatic horizontal positioning by means of switch of the 1<sup>st</sup> right vertical spindle and the fence between the right vertical spindles, in order to execute partial or complete profiles on the 2<sup>nd</sup> right spindle.

# MACHINING UNIT

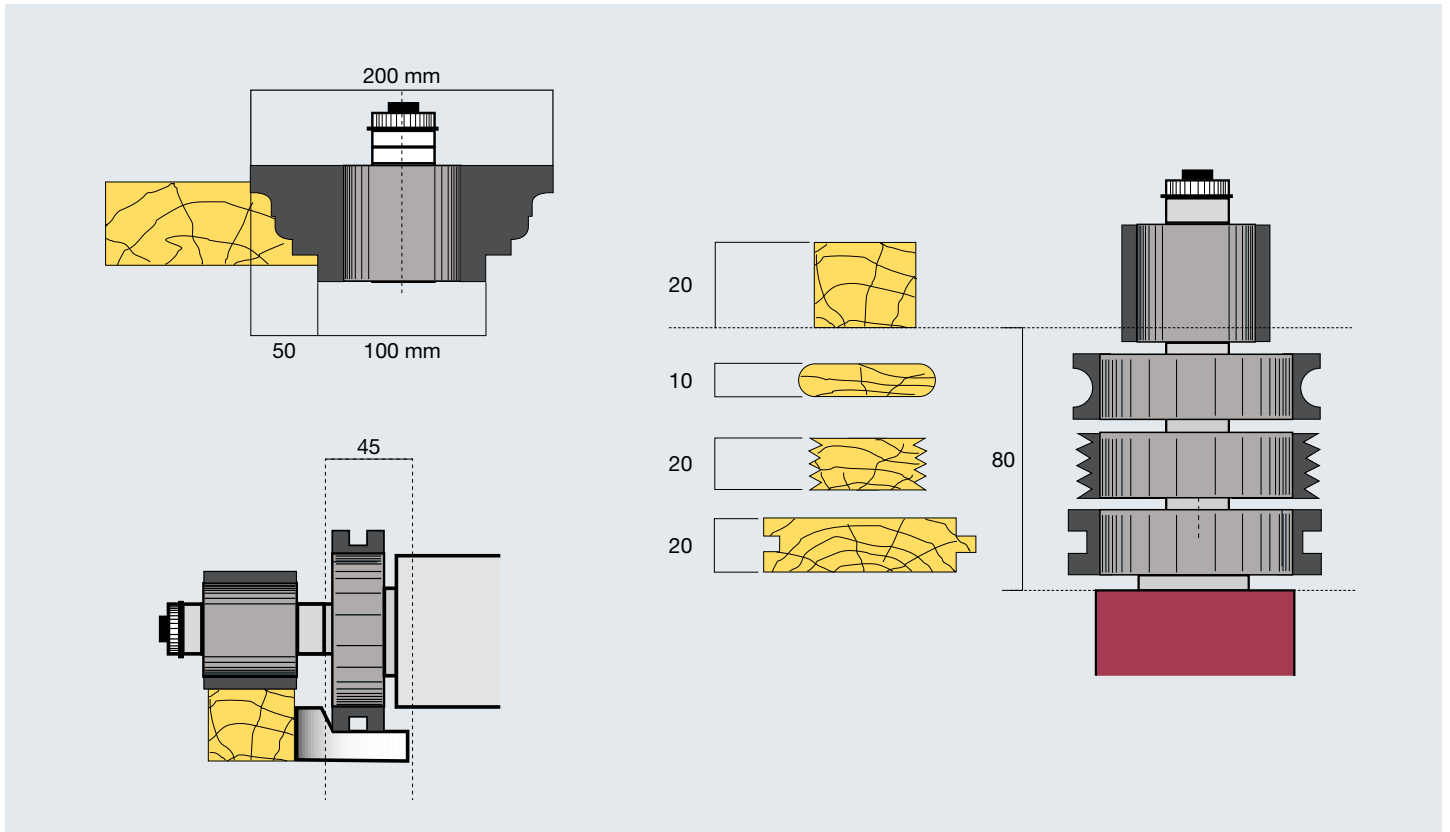

Unrivalled performance: machining units for heavy stock removal, up to 50 mm, and axial strokes of 80 mm on vertical spindles and 45 mm on horizontal spindles, guaranteeing flexibility and variety of achievable products.

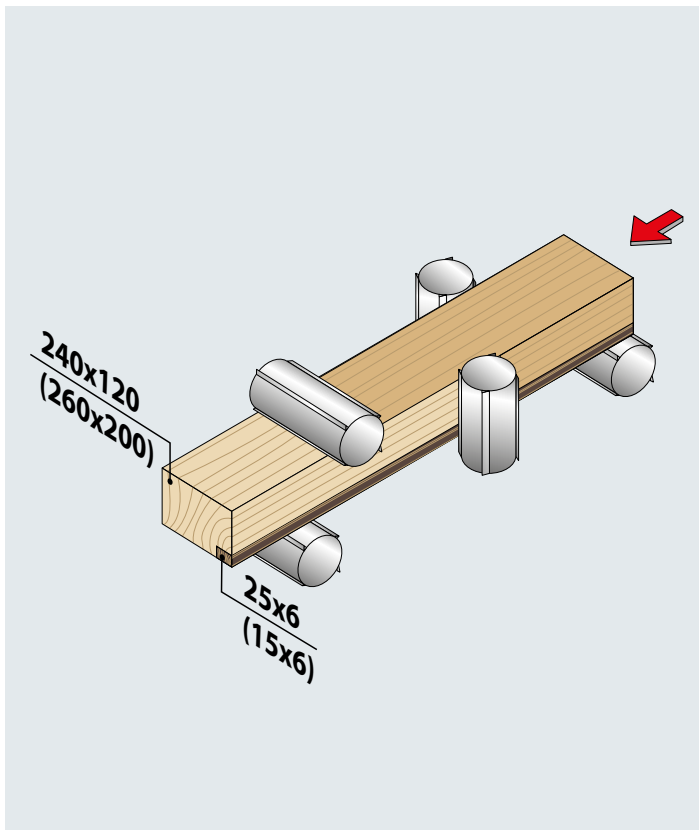

## WORKING CAPACITY

Minimum finished section: 25x6 mm

Maximum finished section: 240x120 mm

Specific options enable to modify the working sections from 15x6 mm for minimum finished section up to 260x200 mm for maximum finished section.





#### **SPINDLES WITH "HSK" TOOL CHUCK**

The technology with rapid locking allows downtime reduction and finish quality enhancement, with improved ergonomics for the operator.



#### **"T-SET" DEVICE**

The locking of tool much simpler and faster, with only the use of a compressed air gun, supplied with the machine.

# MACHINING UNIT

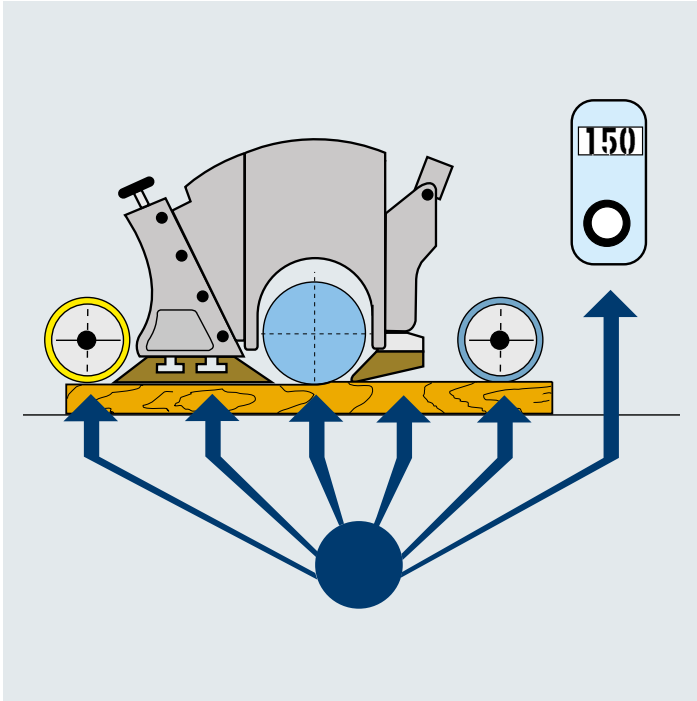

## “SET-UP” SYSTEM

Increased productivity due to the ability to change tools and perform adjustments in just a few seconds, making set-up time up to twenty times faster.





#### **PRESSER SHOES**

Front and rear presser shoes with angular movement are fitted on the top horizontal units to allow the correct work-piece pressure, avoiding undesirable jamming or chattering. The front presser shoe is also provided with pneumatic adjustment.



#### **TWO SECTOR-PRESSER SHOES**

Presser shoe made in two parts with height and width adjustments, for a constant pressure on the work-pieces with varying thicknesses.



#### **MULTI-SECTOR PRESSER SHOE**

Foreseen for the top horizontal spindle, it ensures high finish quality. It is also available the device for the adjustment of the multi-sector presser shoe, that simulates the working conditions on the machine.



# MACHINING UNIT

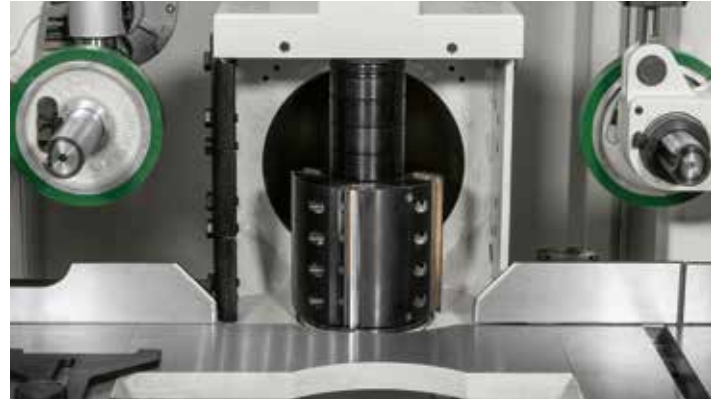

## UNIVERSAL SPINDLE WITH ELECTRONIC ADJUSTMENT OF THE AXES

It is available in models equipped with MOBILE PC, for a complete control of the process, even more simple and quick for the operator.



## “PRL” ARRANGEMENT

Machining unit in place of the universal spindle for the automatic switching (on/off) from planing to the profiling-glazing bead recovering function.

It is also available with electronic axes, for total flexibility.



#### **“TTL” ADJUSTMENT DEVICE**

It enables to process sequences of work-pieces with different widths, without stopping the machine to reset different measurements, saving a large amount of time. The device includes touch probe placed at the infeed, and a special fence out-feed at the left vertical spindle, which provides the correct pressure on the work-piece.



For compositions with two top horizontal spindles, a 2<sup>nd</sup> right vertical spindle is available, with or without the universal spindle option.

# MACHINING UNIT



## **CORNER CHAMFERING UNIT**

Supplementary machining unit placed after last top horizontal spindle, for the corner chamfering of work-pieces with variable dimensions, without the necessity of tool change.



## **MULTI-BLADE CUTTING**

Equipment for vertical cutting of work-pieces with bottom horizontal spindle; it is possible to execute up to five cuts.



### **INDEPENDENT MOTORS**

Each machining unit has its own motor, in order to select the optimal power for each one.



### **MILLIMETER LINES**

They help the operator with manual positioning.  
On models fitted with MOBILE PC, the software displays all the adjustments during the changes.



### **REMOVABLE INSERTS IN FRONT OF THE VERTICAL SPINDLES**

For an excellent finish quality, depending on the tool diameter.

# LOADING AND UNLOADING SYSTEM

## “CS1” FEEDER

Hopper feeder provided with a pusher. A serrated roller, driven by an hydraulic device, feeds work-pieces continuously.



## FEEDER WITH BENCH

It is composed by a set of powered chains for conveying work-pieces to the machine worktable. A pair of powered rollers feeds work-pieces into the machining area.





No idle time with the work-pieces return system, located at the end of the machine.



# M Maestro Digital Systems

SMART SOFTWARE AND DIGITAL SERVICES TO ENHANCE PRODUCTIVITY OF WOODWORKING AND FURNITURE INDUSTRIES.

**Maestro** active

**Factory**

## SOFTWARE

**Simple, smart and open.**

Maestro software are tailored on the machine technology as well as on the entire process. All Maestro software share a common mission:

**easy to use**, so that any operator can easily and confidently learn and use the software

**smart**, with algorithms and computing modules aiming at the best possible result

**open** in order to integrate existing software, and provide customer the coverage of all his process.

SCM accompanies woodworking companies throughout their whole process combining machines with matching software solutions and digital services, with a constant strive to enhance company productivity.

The software solutions powered by SCM are developed to optimize machine usage as well as the entire process, providing integration with the different software existing in the company.



**Console eye-M: smart, fair, interactive, effortless, revolutionary**

SCM innovative touch screen console eye-M allows a comfortable easy navigation and use of the standardized user interface Maestro active.

Console eye-M is characterized by a Full HD LCD (21.5") display to ensure an effortless, convenient experience.



# Maestro active 4-side

Maestro active is the new operator interface software which has been unified across all SCM technologies. A single operator can easily and confidently run multiple machines due to controller and interface consistency: regardless the machine, Maestro active maintains the same *look&feel*, with many identical icons and navigation buttons, thus ensuring the same approach to interaction.

## EASE OF USE

The new interface has been specifically designed and optimized for immediate use via touch screen. Graphics have been redesigned for simple and comfortable navigation, with tablet-like icons on touch screen controller.

## “ZERO” ERRORS

Improved productivity thanks to guided procedures that reduce the possibility of error from the operator's side.

## SOFTWARE

## Factory

# Maestro active 4-side

The MOBILE PC electronic control allows intuitive machine programming, combining the eye-M console and the Maestro active 4-side software.

## FULL CONTROL OF PRODUCTION PERFORMANCES

The creation of customizable reports by operator, shift, program, forecast period (and much more) allows to monitor, optimize and improve the production performance.

## ORGANIZE YOUR PRODUCTION

Maestro active 4-side allows to create different users with different roles and authorizations (e.g.: operator, maintainer, administrator, ...).

Any user can only execute the functions whose permissions have been assigned to him. It is also possible to define the work shifts on the machine and then detect activities, productivity and events that occurred in each shift.

## TOTAL QUALITY OF THE FINISHED PRODUCT

With Maestro active 4-side the quality of the finished piece is no longer put at risk by worn tools. The new Maestro active Tool Life Determination system sends notification messages as the tool reaches its end of life and recommends its replacement at the most appropriate time.

## TOOLS? NO PROBLEM!

Maestro active 4-side guides the operator during the tool change phase, taking into account the programs to be executed.

## EASY TO USE

Main functions:

- customization of layout and options, specific to each machine composition
- tool library without number limits, with import of profile image
- work programs without number limits, with import of profile image
- MDI (Memory Data Input) function for guided manual adjustment of axes
- axes management with electronic adjustment, speed of towing, power on/off of motors, spindle rotation speed (if the inverter is provided)
- tele-service and input/output display
- detailed reporting on the machine use
- guided operations by software during manual machine set-up

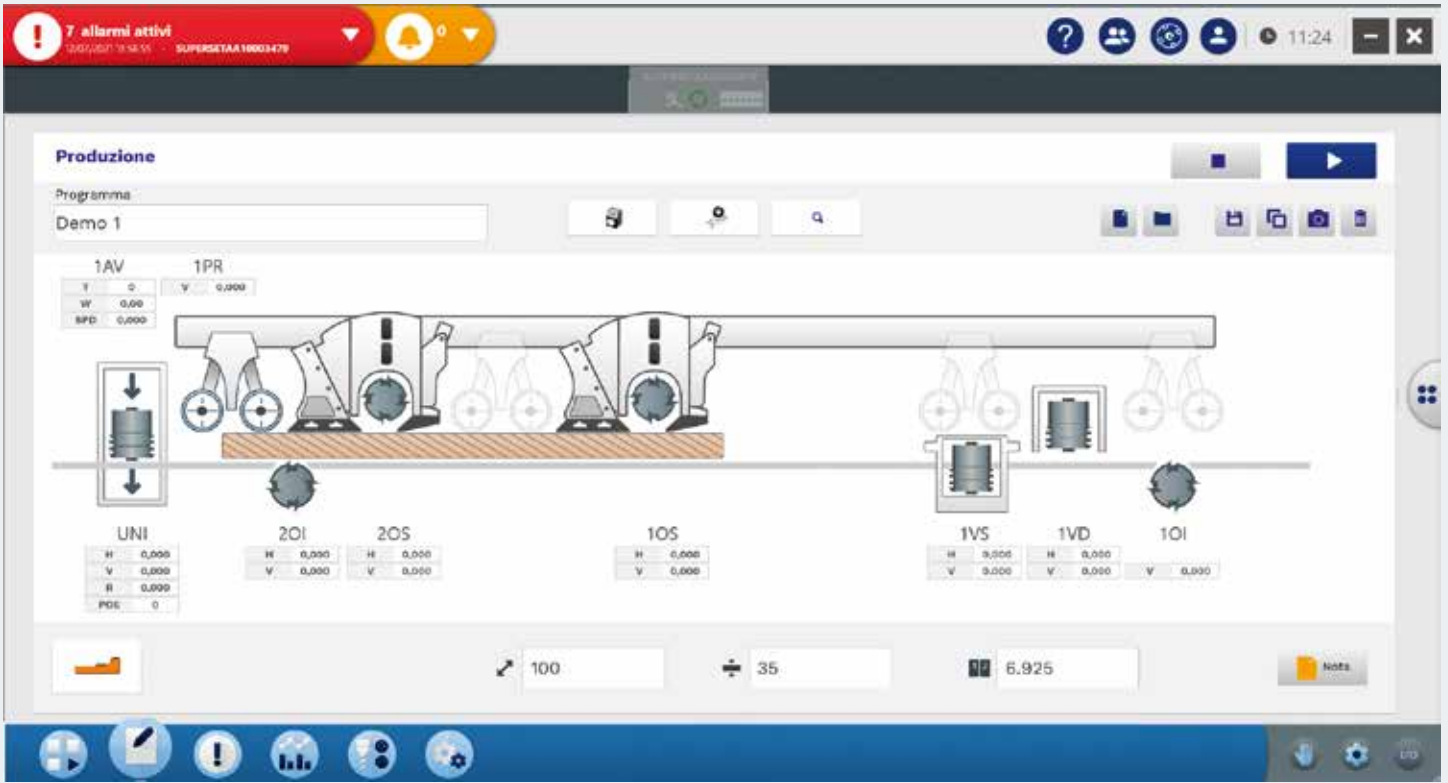

Customization of layout and options, specific to each machine composition.

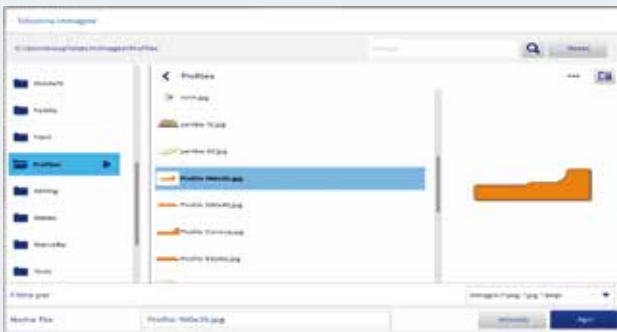

Profile image management.



Tool image management.



Tele-service and input/output display.



Guided operations by software during manual machine set-up.



MDI (Memory Data Input) function for guided manual adjustment of axes.



Display of the tools wear status.

# ELECTRONIC CONTROLS



## PRESET 50

Device for measuring min./max. tool diameter and tools axial position.

Thanks to "GT SOFT" software, it is possible to elaborate the data and directly update the tool charts of the machine with MOBILE PC.



## LABEL PRINTER

Complete work cycle with the possibility to manually apply the label on the outfeed work-piece (after the machining) to provide identification for subsequent operations.



## BARCODE READER

Quick and easy scanning of labels applied to the work-pieces by using the barcode reader.



### CONTROL 10

Electronic control based on industrial PLC, with 7" colour touch screen monitor.

Main functions:

- programming by menu with icons
- customization of layout and options, specific to each machine composition
- management of up to 8 electronic axes
- pre-arrangement for tele-service and input/output display
- backup for data saving and restoring
- storage of 999 programs
- storage of 999 tools

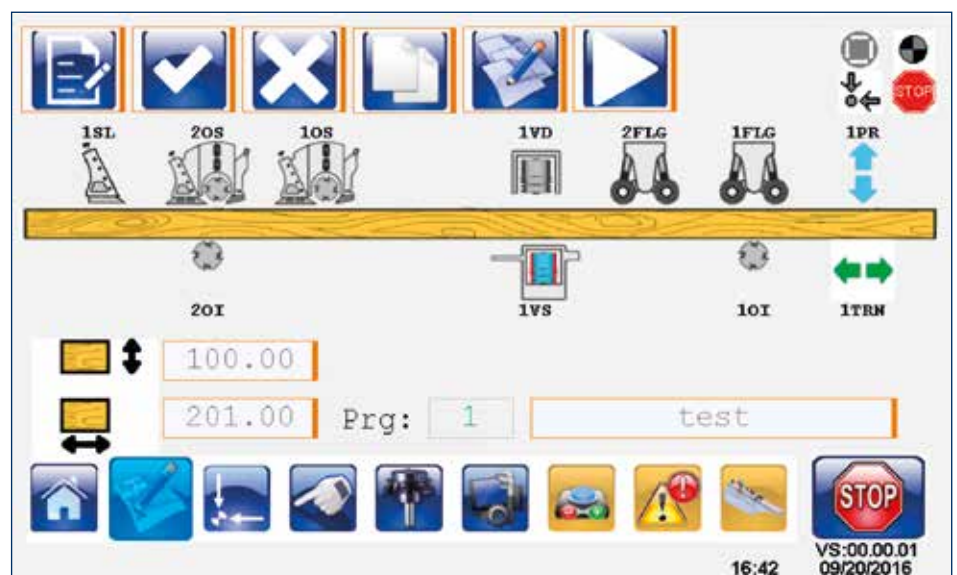

# LAYOUT

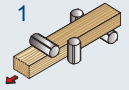
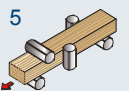
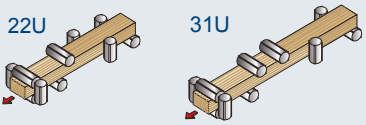
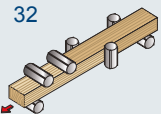
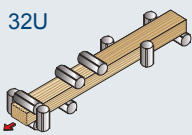
Machine composition	A (mm)	B (mm)	C (mm)	D (mm)	Weight (kg)
	4243	1770	2375	1656	2400
	5060	1770	2375	1656	3200
	4243	1770	2375	1656	2700
	5060	1770	2375	1656	3500
	4864	1770	2375	1656	3500
	5680	1770	2375	1656	4100
	5483	1770	2375	1656	4600
	6298	1770	2375	1656	5200

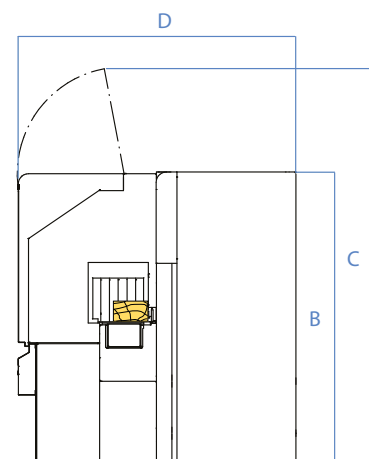
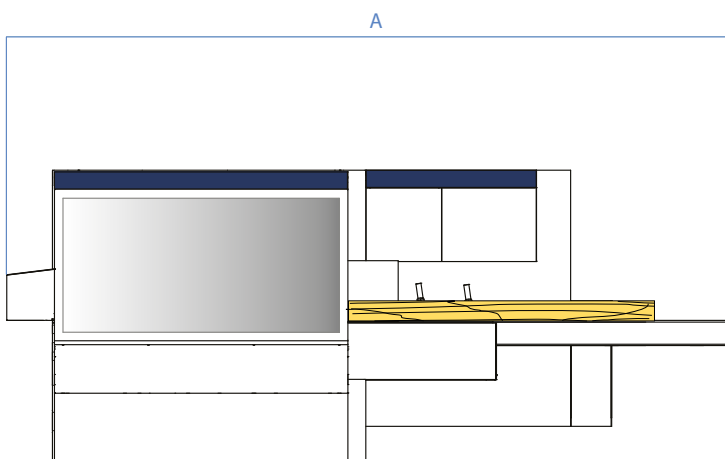



superset nt		
Minimum working width (finished section)	mm	25 [15 opt.]
Maximum working width (finished section)	mm	240 [260 opt.]
Minimum working thickness (finished section)	mm	6
Maximum working thickness (finished section)	mm	120 [200 opt.]
Feed speed	m/min	5 ÷ 25 [6 ÷ 40 opt.]
Motors power	kW (HP)	4 (5,5) [up to 18,5 (25) opt.]
Spindles rotation speed	rpm	6000 [8500 opt.]
Tool-holder spindles diameter	mm	40 [50 opt.]
Axial adjustment of vertical spindles from worktable	mm	80 [75 opt. with HSK]
Axial adjustment of horizontal spindles from right fence	mm	45
Min./max. profiling tool diameter	mm	100/200



**COMPANY WITH  
QUALITY SYSTEM  
CERTIFIED BY DNV  
= ISO 9001 =**

*The technical data can vary according to the requested machine composition. In this catalogue, machines are shown with options. The company reserves the right to modify technical specifications without prior notice; the modifications do not influence the safety foreseen by the CE Norms.*

Maximum noise levels measured according to the operating conditions established by ISO 7960 - 1995 / H.  
Acoustic pressure in process 85 dB(A) (measured according to EN ISO 11202:1995, uncertainty K = 4 dB).  
Acoustic power in process 101 dB(A) (measured according to EN ISO 3746: 1995, uncertainty K = 4 dB).





Even if there is a correlation between above mentioned "conventional" noise emission values and average levels of personal exposure over eight hours of operators, these last also depend on the real operating conditions, duration of exposure, acoustic conditions of the working environment and presence of further noise sources, this means the number of machines and other adjacent processes.

# WE'LL GO THE EXTRA MILE FOR YOU



SCM OFFERS A FULL RANGE OF **HIGHLY SPECIALISED SERVICES** WITH A QUALITY AND RELIABILITY THAT STEM FROM 70 YEARS OF EXPERIENCE IN THE INDUSTRY.

From installation and production start-up to services and maintenance. From training to the supply of specific original spare parts: **we provide solutions designed around you!**

 <p><b>SERVICE AND MAINTENANCE</b></p> <ul style="list-style-type: none"> <li>• Remote support</li> <li>• Scheduled maintenance contracts</li> <li>• Warranty extension</li> </ul>	 <p><b>TRAINING SERVICE</b></p> <ul style="list-style-type: none"> <li>• Courses for machine operators</li> <li>• Software and programming courses</li> <li>• Training in production start-up</li> </ul>
 <p><b>SPARE PARTS</b></p> <ul style="list-style-type: none"> <li>• Recommended spare parts list</li> <li>• E-shop</li> <li>• Interactive spare-parts catalogues</li> <li>• Repairs on electronic parts, glue tanks and electro-spindles</li> </ul>	 <p><b>DIGITAL SERVICES</b></p> <ul style="list-style-type: none"> <li>• Maestro Connect - IoT platform to be constantly connected with your machines</li> <li>• Smartech - assistance with augmented reality</li> <li>• My Scm portal - opening of service ticket and single point of access to the apps and Services tools</li> </ul>

**CONTACT**

**SCM SERVICE**

via Emilia 77 - 47921 Rimini - Italy  
 tel. +39 0541 700100  
 scmsservice@scmgroup.com  
 www.scmwood.com

**SCM SPAREPARTS**

Via Casale, 450 - 47826 - Villa Verucchio (RN) - Italy  
 tel. +39 0541 674111  
 spareparts@scmgroup.com  
 www.scmwood.com



# THE STRONGEST WOOD TECHNOLOGIES ARE IN OUR DNA

## SCM. A HERITAGE OF SKILLS IN A UNIQUE BRAND

70 years of success gives SCM the centre stage in woodworking technology. This heritage results from bringing together the best know-how in machining and systems for wood-based manufacturing. SCM is present all over the world, brought to you by the widest distribution network in the industry.

**70** years history

**3** main production sites in Italy

**300.000** square metres of production space

**20.000** machines manufactured per year

**90%** export

**20** foreign branches

**400** agents and dealers

**500** support technicians

**500** registered patents

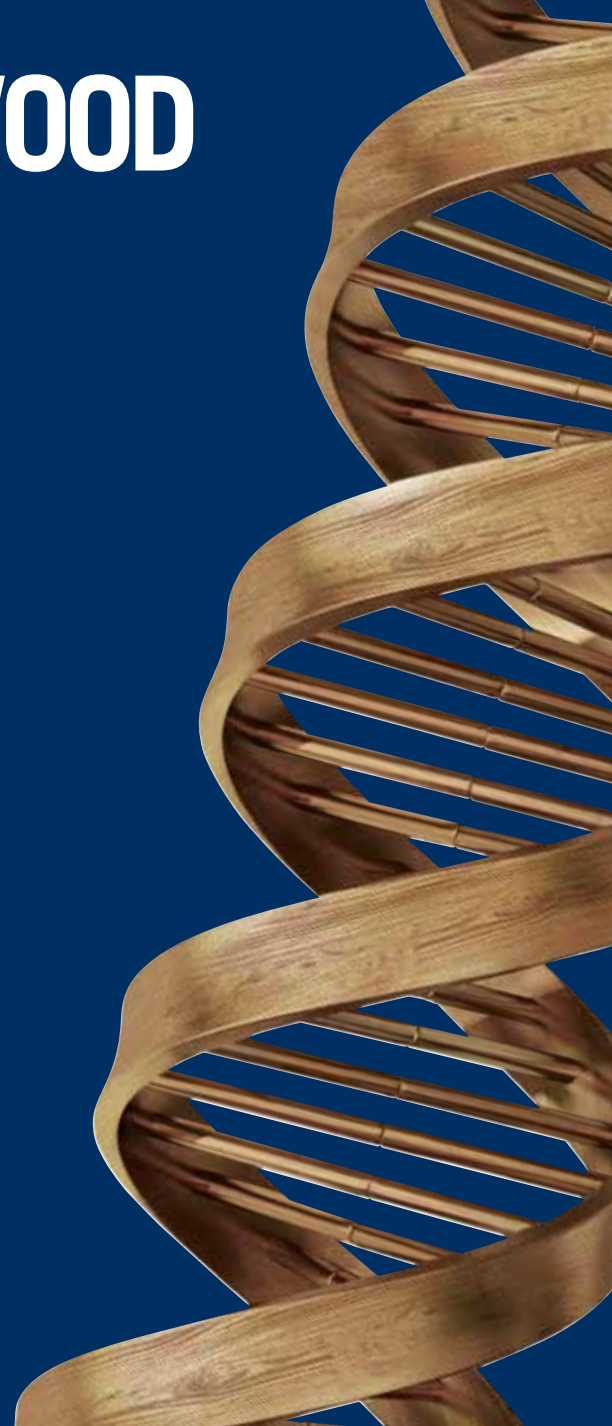

In SCM's DNA also strength and solidity of a great Group. The SCM Group is a world leader, manufacturing industrial equipment and components for machining the widest range of materials.

## SCM GROUP, A HIGHLY SKILLED TEAM EXPERT IN INDUSTRIAL MACHINES AND COMPONENTS

### INDUSTRIAL MACHINERY

Stand-alone machines, integrated systems and services dedicated to processing a wide range of materials.



WOODWORKING TECHNOLOGIES



TECHNOLOGIES FOR PROCESSING  
COMPOSITE MATERIALS, ALUMINIUM,  
PLASTIC, GLASS, STONE, METAL

### INDUSTRIAL COMPONENTS

Technological components for the Group's machines and systems, for those of third-parties and the machinery industry.



SPINDLES AND  
TECHNOLOGICAL  
COMPONENTS



ELECTRIC PANELS



METALWORK



CAST IRON



**SCM GROUP SPA**

via Casale 450 - 47826 Villa Verucchio, Rimini - Italy  
tel. +39 0541 674111 - fax +39 0541 674274  
scm@scmgroup.com  
www.scmwood.com



00L0372849C